

A Division of the Angelus Corporation  
 Ph (262) 246-0500 Fax (262) 246-0450 www.picwire.com  
 W220N1051 Springdale Road, Waukesha, WI 53186

Approved : *JDA*  
 Distribution : USER

Date: 4/27/2021  
 Rev.: 0  
 Uncontrolled if Printed

**N-Type 90° Plug**  
 for S31601

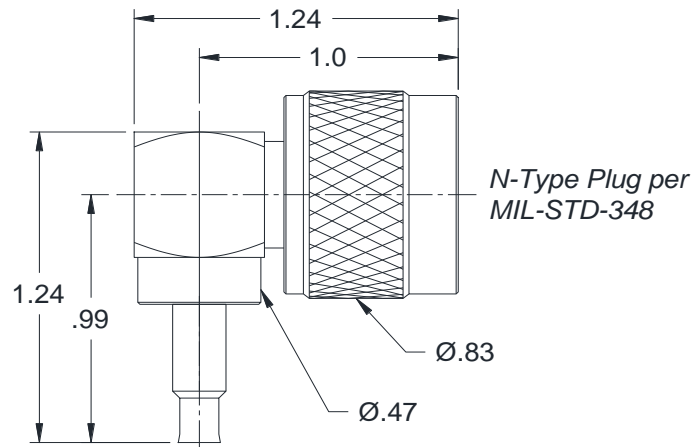

Threaded end-cap and gasket not shown.

**PERFORMANCE**

Nominal Impedance :	50 Ohms
Frequency Range :	0 - 2.5 GHz
Dielectric Withstanding Voltage :	2500 V (rms)
Insulation Resistance :	5000 Megohms min.
Insertion Loss :	$0.095 \sqrt{F(GHz)}$
Temperature Rating :	-65° C to 165° C

**CONNECTOR WEIGHT (Each)**

1.65 ounces (46.9 grams)

**RoHS COMPLIANT**

Complies to RoHS Standards

**INSTALLATION****Center Contact**

Solder only.

**Crimp Ferrule**

M22520/5-01 Tool  
 M22520/5-09 Hex Crimp Die  
 Cavity A (.178" Hex)

**CONSTRUCTION****Materials:**

Coupling Nut	Brass
Dielectric	PTFE/ULTEM
Gasket	Silicone Rubber
Retainer Ring	Phosphor Bronze
Center Contact	Brass
Body	Brass
Cover	Brass
Ferrule	Brass

**Finish :**

Coupling Nut	Nexcote
Center Contact	Gold
Body	Nexcote
Cover	Nexcote
Ferrule	Nexcote

**APPLICABLE STANDARDS**

MIL-STD 348  
 MIL-PRF-39012

**Notes :**

1) A 1.0" piece of Raychem ATUM heat shrink P/N ATUM-8/2-0 provided with connector for purpose of strain relief & moisture protection.

2) Please refer to T-111136 Termination Instruction sheet for strip dimensions & instructions.