

PIC Wire & Cable	Connector Specification	P/N 190839-01
A Division of the Angelus Corporation Ph (262) 246-0500 Fax (262) 246-0450 www.picwire.com PO Box 330 Sussex, WI 53089	Approved : 	Date : 06/25/12
	Distribution : USER	Rev : 6 (09/19/18)
		Uncontrolled if Printed

M39029 Size 8 Coaxial Socket Contact
for PIC Cables S86208 / S88207 / S83204

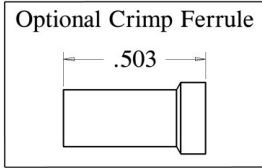
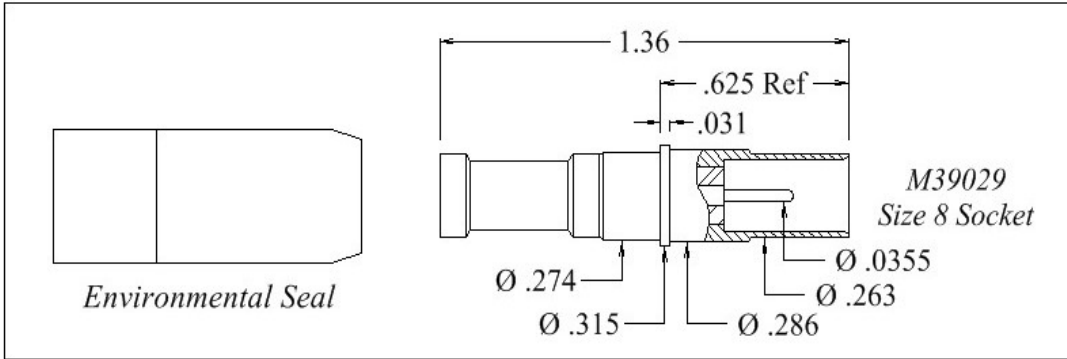

PERFORMANCE

Nominal Impedance	50 Ohms
Frequency Range	0 - 6 GHz
Voltage Rating	750 V(rms)
Insulation Resistance	5000 Megohms
Dielectric Withstanding Voltage	1300 V(rms)
VSWR (max)	1.3:1
Insertion Loss (max)	0.3 dB

CONNECTOR WEIGHT (Each)

0.27 ounces (7.63 grams)

RoHS COMPLIANT

Complies to RoHS Standards

INSTALLATION (Tooling)

Center Contact

M22520 / 2 - 01 Tool,
Selector Dial @ # 8
Recommended Positioner :
PIC # 110407 (Daniels # K1682)

Weatherproofing Crimp Ferrule

M22520 / 5 - 01 Tool,
PIC 190818 Hex Crimp Die
(.186/.222 hex)

Optional Crimp Ferrule

M22520 / 5-01 Tool,
*MIL Spec M22520 / 5-09
(.178 A hex)

CONSTRUCTION

Materials:

Body	Beryllium Copper, ASTM-B196, Alloy UNS C17300
Center Contact	Brass, ASTM-B16, Alloy UNS 36000, H02
Ferrule	Brass, ASTM-B16, Alloy UNS 36000, Dead Soft, Weatherseals included
Dielectric	TFE Fluorocarbon, ASTM-D1710, Type 1, Grade 1
Environmental Seal	Thermoplastic & Elastomer

Finish :

Body, Ferrule	Gold
Center Contact	Gold

APPLICATIONS

MIL-DTL-38999 Series I, III, IV
SAE-AS39029/59

Notes :

- 1) Please refer to T-1908XX Termination Instruction sheet for strip dimensions & instructions.
- 2) Removal Tool P/N M81969/14-12

* Note - MIL Spec die to be used on smaller diameter area of "optional" crimp ferrule only. Not the larger "Bell" area on end.